

# Mechanical Principles of Wheelchair Design

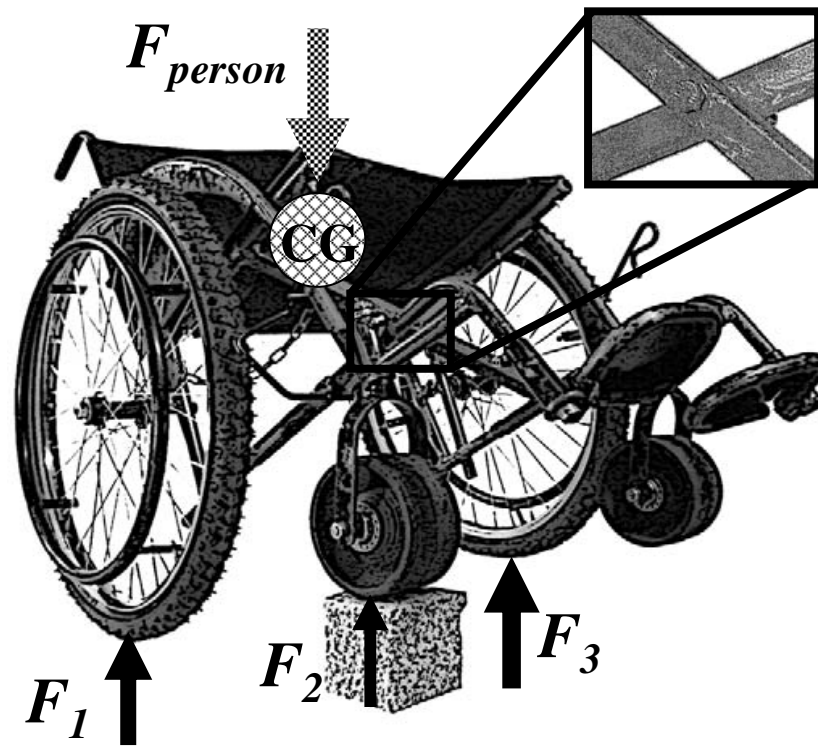

**Amos Winter**

**Graduate Student, Department of Mechanical Engineering  
Massachusetts Institute of Technology**

**Ralf Hotchkiss**

**Chief Engineer  
Whirlwind Wheelchair International**

*This manual is free to anyone. Please photocopy and distribute.*

# Forces



## Where useful

Seat

Frame

Wheels

Footrests

## Description

A force is the amount one object tries to push or pull another object. The earth exerts a force on every object, pulling it towards the ground. This is known as the force due to gravity. When you measure the weight of a person, you are measuring the force of gravity pulling on him. When an object is stationary all the forces acting on it are balanced. When the forces are not balanced, the object will move. Forces are measured in Newtons or pounds. To convert kilograms to Newtons, multiply the number of kilograms by 9.81. One kilogram is equal to 2.2 lbs.

$$F_{orange} = 2N$$

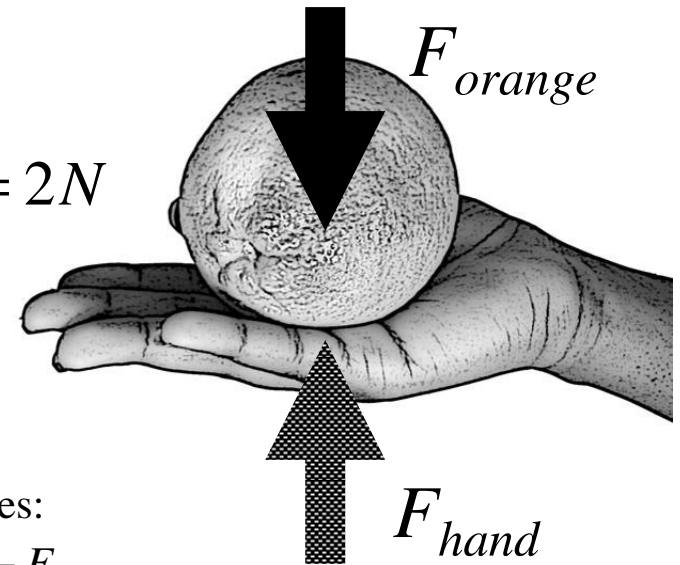

Add forces:

$$0 = F_{hand} - F_{orange}$$

$$0 = F_{hand} - 2N \Rightarrow F_{hand} = 2N$$

## Example: Holding an orange

When you hold an orange you feel the force of gravity trying to pull it to the ground. Your hand has to push up on the orange to keep it from falling. The force the orange exerts on your hand is equal in amount and opposite in direction to the force your hand is exerting on the orange (see the equation). When you put the orange on a table, now the table is pushing on it with an equal and opposite force. When you drop the orange the forces on it are unbalanced. The orange falls because the force of gravity pulls it to the ground.

# Center of gravity

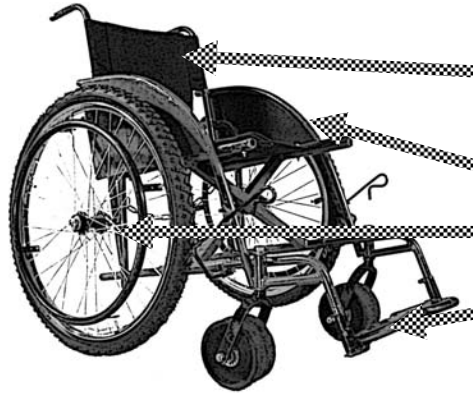

## Where useful

Seat

Frame

Wheels

Footrests

## Description

The center of gravity (CG) of an object is the point where it can be balanced. If you wanted to think of gravity pulling on an object at a single point, the CG is that location. Understanding CG location is important in wheelchair design. You can approximate the force a person exerts on a wheelchair as his total weight applied at the CG of his body, which is a point around his hips.

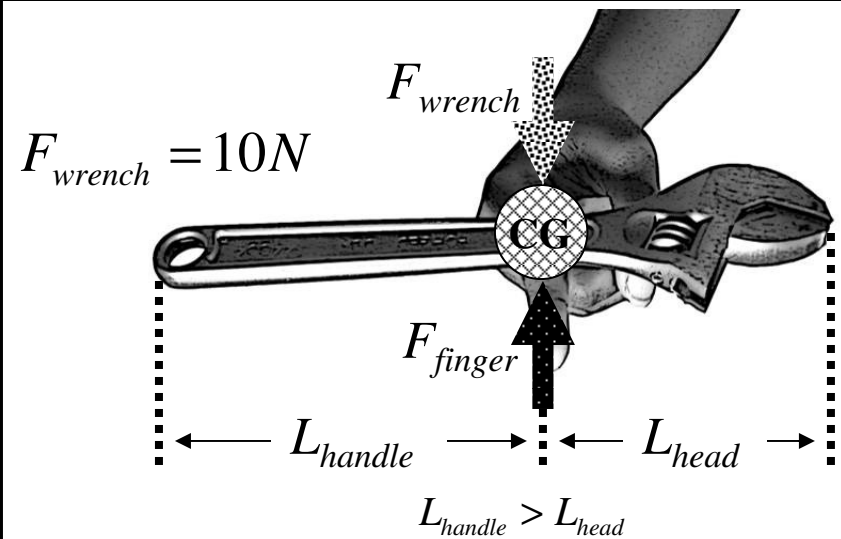

Add forces:

$$0 = F_{finger} - F_{wrench} \Rightarrow F_{finger} = 10N$$

## Example: Find the CG of a wrench

The CG of the wrench is the point where the wrench can be balanced. More mass is concentrated at the head, which makes the CG closer to the head and not at the center of the handle.

# Free body diagram



## Where useful

Seat

Frame

Wheels

Footrests

## Description

A free body diagram (FBD) is a visual representation of the forces acting on an object. You have already seen FBDs in the previous examples. As in the case of stationary objects, like the orange and wrench example, there are forces acting on them to balance the force of gravity pulling them to the ground.

$$F_{person} = 500N$$

Add forces:

$$0 = 2F_{caster} + 2F_{wheel} - F_{person}$$

$$F_{wheel} = ?$$

$$F_{caster} = ?$$

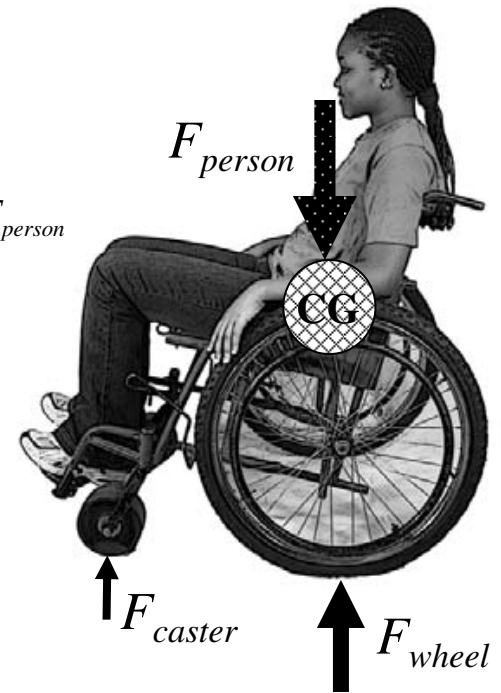

## Example: Sitting in a wheelchair

The figure shows the FBD of a person in a wheelchair. If you know the weight of the person you know the force her body exerts on the wheelchair. Because the wheelchair is not moving the forces the ground exerts on the wheels and casters must add up to be equal and opposite to the force from the person's weight (note the "Add forces" equation is for 2 wheels and 2 casters). In the next sections you will learn how to calculate the forces exerted by the ground on the wheels and casters.

# Moments



## Where useful

Frame

Wheels

## Description

A moment is like a force, but instead of trying to push an object it tries to twist it. A moment is a force applied to a lever arm. When you tighten a bolt, you apply a moment to the bolt with a wrench. You produce the force with your body and the lever arm is the handle of the wrench. The moment is calculated by multiplying the force times the perpendicular (at a 90° angle) distance from the pivot point. In every FBD, if the object is stationary, both the forces and moments need to add up to zero.

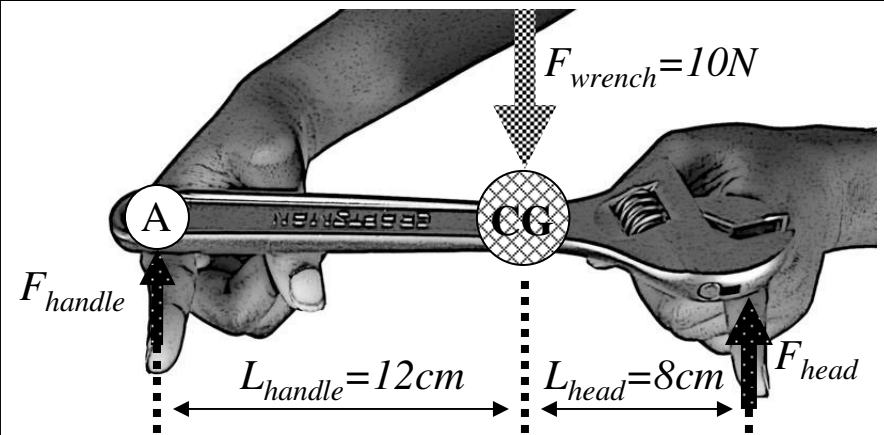

$$\text{Add forces: } 0 = F_{\text{handle}} + F_{\text{head}} - F_{\text{wrench}} = F_{\text{handle}} + F_{\text{head}} - 10\text{N}$$

$$\text{Add moments: } 0 = F_{\text{wrench}}(L_{\text{handle}}) - F_{\text{head}}(L_{\text{handle}} + L_{\text{head}})$$

$$F_{\text{head}} = \frac{F_{\text{wrench}}(L_{\text{handle}})}{(L_{\text{handle}} + L_{\text{head}})} = \frac{10\text{N}(12\text{cm})}{(12\text{cm} + 8\text{cm})} = 6\text{N} \Rightarrow F_{\text{handle}} = 4\text{N}$$

## Example: Find forces with moments

Support a wrench on two fingers, as shown in the figure above. Since the object is not moving we know the moments at each point must add up to zero. Calculating moments from point A, the moment from the weight of the wrench, which acts at the CG, tries to make the wrench spin clockwise. The moment from our finger under the head tries to make the wrench spin anticlockwise (negative direction). Knowing the moments add to zero we can calculate the force at the head. Use the addition of vertical forces to find the force at the handle.

Add forces:

$$0 = 2F_{casters} + 2F_{wheels} - F_{person}$$

$$0 = 2F_{casters} + 2F_{wheels} - 500N$$

Add moments:

$$0 = F_{person}(L_{caster}) - 2F_{wheel}(L_{caster} + L_{wheel})$$

$$F_{wheel} = \frac{F_{person}(L_{caster})}{(L_{caster} + L_{wheel})}$$

$$F_{wheel} = \frac{500N(40.6cm)}{(40.6cm + 10.2cm)} = 200N$$

$$\Rightarrow F_{caster} = 50N$$

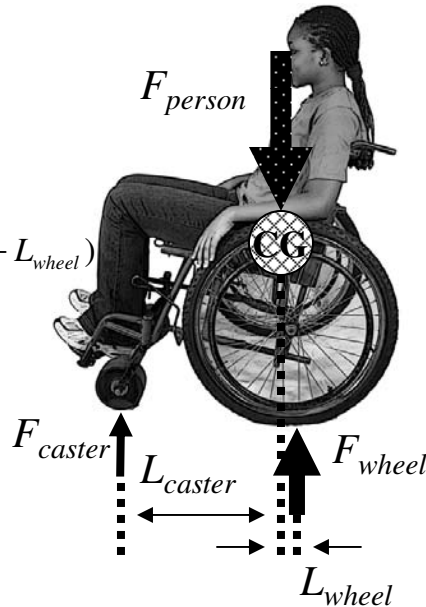

Tipping angle:

$$\tan \theta_{tip} = \frac{A}{B} \Rightarrow \theta_{tip} = \arctan\left(\frac{A}{B}\right)$$

Can also calculate  $\theta_{tip}$  from height wheels lift off ground

$$\theta_{tip} = \arcsin\left(\frac{h_{tip}}{2A}\right)$$

Tipping angle and height for different chairs geometries:

A/B	$\theta_{tip}$	$h_{tip}$
0.3	17°	11cm
0.4	21°	18cm
0.5	27°	28cm

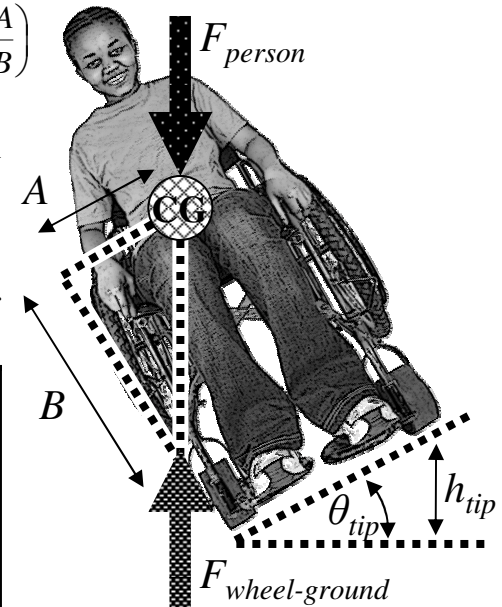

## Example: Forces on a wheelchair

Find the forces acting on the wheels of the wheelchair in the above figure. If you know the weight of the person in the chair, the location of her CG, and the distance between the wheels, you can calculate the forces on the wheels by using moments. The calculations in the example above add the moments about the front caster.

## Example: Wheelchair tipping angle

A wheelchair will tip over when the forces and moments acting on the chair become unbalanced. When the wheelchair tips to a point where the CG of the user is vertically aligned with the point where the wheel contacts the ground, the chair is unstable. The angle the wheelchair makes with the ground at this point is called the tipping angle ( $\theta_{tip}$ ), as shown in the figure above. If the wheelchair tips further it will fall over because there is no moment to counteract the moment generated by the CG.

# Internal forces



## Where useful

Frame

Wheels

## Description

Forces and moments also act on the inside of an object. We can use the same methods as in the previous examples to find internal forces and moments. If an object is stationary, you know that all the forces and moments have to balance each other. There are some different terms used to describe what occurs inside an object: Forces that try to stretch or compress an object are called tensile (stretch) and compressive (compress) forces. Forces trying to tear the object are called shear forces. Moments are still called moments on the inside of the object.

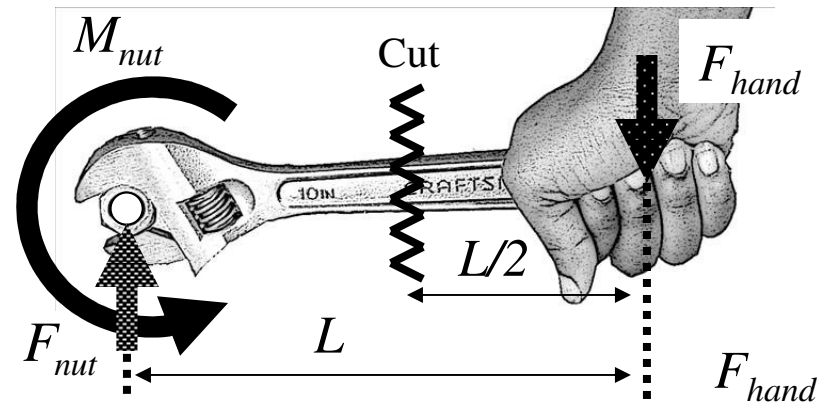

Add forces:

$$F_{nut} = F_{cut} = F_{hand}$$

Add moments:

$$M_{nut} = F_{hand}(L), \quad M_{cut} = F_{hand}\left(\frac{L}{2}\right)$$

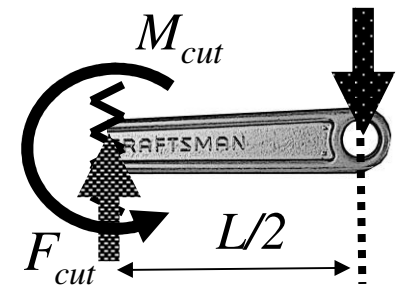

## Example: Moments inside a wrench

The moment a wrench applies to a nut is the force multiplied by the length of the handle. There is a moment at the head but no moment at the end of the handle. Now imagine taking a cut of the wrench and drawing a FBD of both pieces, which are stationary. The forces and moments that act on the surface where the cut was made on one piece are equal and opposite to those on the cut surface of the other piece. Imagine cuts at different places along the wrench and notice the internal moment decreases from the head to the handle.

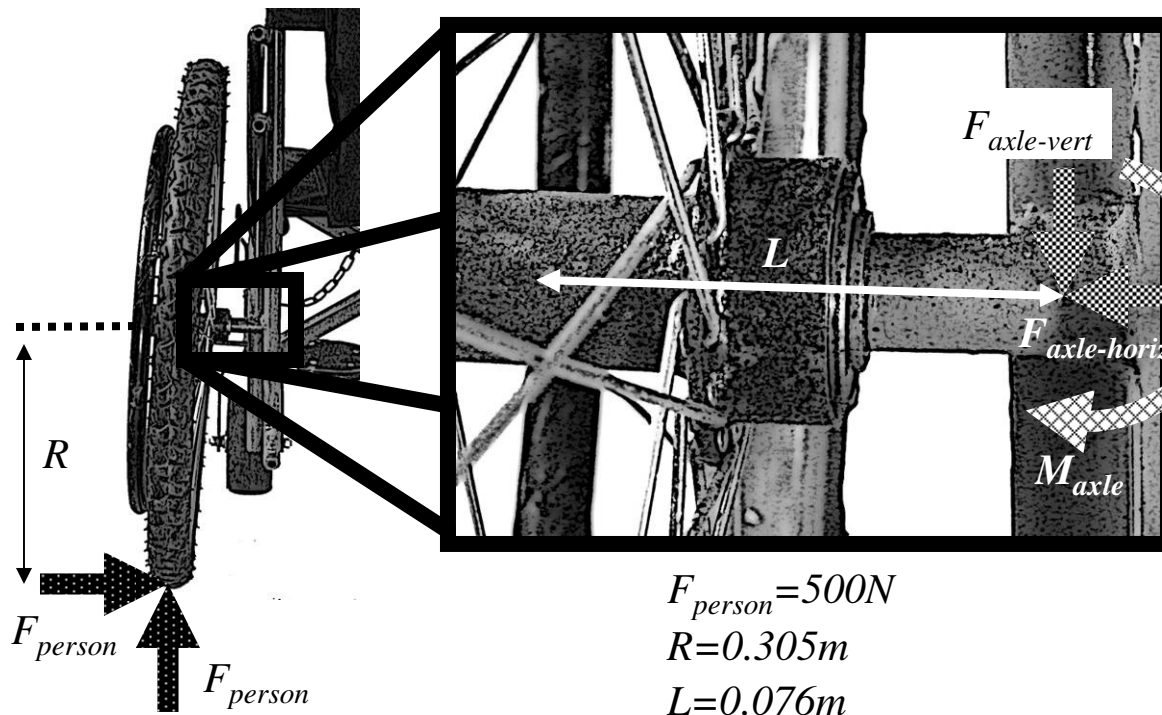

Add forces:

$$0 = F_{person} - F_{axle-horiz} \Rightarrow F_{axle-horiz} = 500N$$

$$0 = F_{person} - F_{axle-vert} \Rightarrow F_{axle-vert} = 500N$$

Add moments:

$$0 = F_{person}(L) - F_{person}(R) + M_{Axle}$$

$$M_{axle} = F_{person}(R - L)$$

$$M_{axle} = 500N(0.305m - 0.076m)$$

$$M_{axle} = 114.5N \cdot m$$

## Example: Internal moments and forces in a wheelchair axle

The forces and moments acting on the rear axle of a wheelchair can be calculated the same way as for the wrench in the previous example. The maximum moment occurs where the axle is welded to the frame. Think about what might cause moments on the axle. There are vertical forces exerted on the wheel from the ground, but there also may be horizontal forces that act on the wheel when the chair tips over. The total moment in the axle is difficult to calculate and requires using trigonometry. If you are comfortable with trigonometry determine the moments in the axle when the chair is at the tipping angle. As an estimation, calculate the moments caused from the full weight of a person pushing on one rear wheel, both vertically and horizontally. As you will see in the next sections, the moment in the axle will determine if the metal is strong enough. See the figure for the axle-moment calculation.

# Area, volume, mass

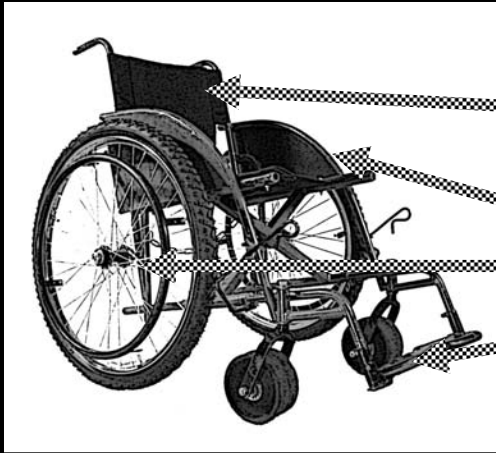

Where useful
Seat
Frame
Wheels
Footrests

## Description

In engineering you often need to calculate the area or volume of a part. Area is important when calculating the stress (see next section) and volume is important when calculating the weight. You can calculate the weight of an object if you know its volume and density. Density is a material property that tells how much mass there is for a given volume. For example, the density of water is 1 gram per each cubic centimeter (written as  $1\text{g/cm}^3$ ) and the density of steel is  $7.8\text{g/cm}^3$ . Steel is heavier than water, thus it sinks. If you want to know the mass of a steel part, you would multiply the density of the steel by the volume of the part.

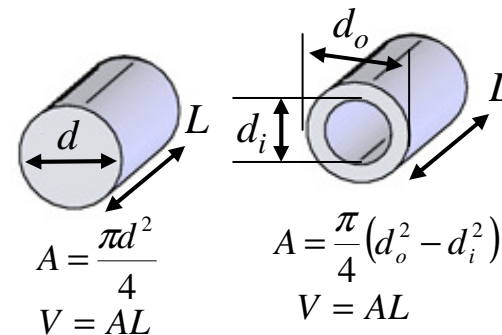
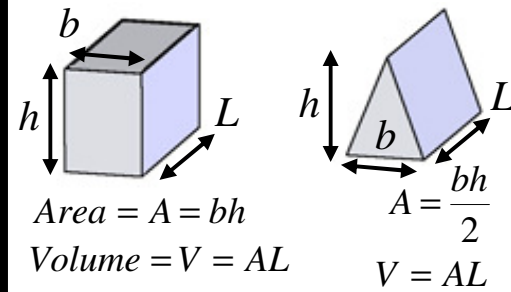

Density =  $\rho$

Material	$\rho(\text{kg/m}^3)$
Steel (mild)	78.7
Alum.	27
Rubber (Butyl)	12
Plastic (PVC)	13

## Example: Calculating mass of a part

For example, if your steel part had the dimensions of 10cm by 10cm by 20cm, the volume would be  $10\text{cm} \times 10\text{cm} \times 20\text{cm} = 2000\text{cm}^3$ . The mass would then be  $7.8\text{g/cm}^3 \times 2000\text{cm}^3 = 15600\text{g}$  (notice the units of  $\text{cm}^3$  cancelled out). 15600g is the same as 15.6kg.

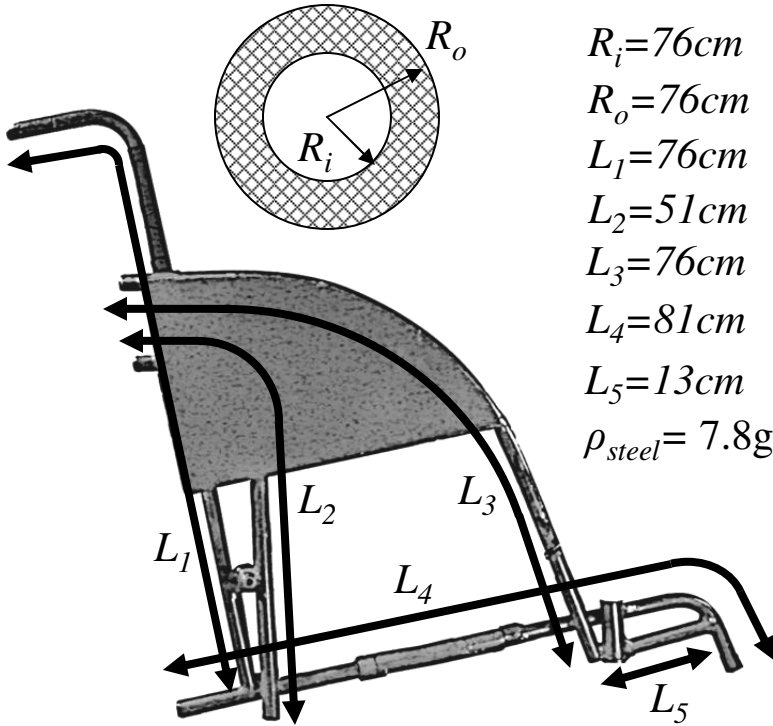

$R_i = 76\text{cm}$   
 $R_o = 76\text{cm}$   
 $L_1 = 76\text{cm}$   
 $L_2 = 51\text{cm}$   
 $L_3 = 76\text{cm}$   
 $L_4 = 81\text{cm}$   
 $L_5 = 13\text{cm}$   
 $\rho_{\text{steel}} = 7.8\text{g/cm}^3$

Find the area of the frame tubing:

$$A = \pi(R_o^2 - R_i^2) = \pi(0.95^2 - 0.76^2) = 1.02\text{cm}^2$$

Find the total length of frame tubing:

$$L_{\text{total}} = L_1 + L_2 + L_3 + L_4 + L_5$$

$$L_{\text{total}} = 76\text{cm} + 51\text{cm} + 76\text{cm} + 81\text{cm} + 13\text{cm}$$

$$L_{\text{total}} = 297\text{cm}$$

Find the volume of steel:

$$V = A \cdot L_{\text{total}} = 1.02\text{cm}^2 \cdot 297\text{cm} = 303\text{cm}^3$$

Find the mass of the frame:

$$m = \rho_{\text{steel}} V = \frac{7.8\text{g}}{\text{cm}^3} \cdot 303\text{cm}^3 = 2363\text{g} = 2.36\text{kg}$$

### Example: Mass of one side of wheelchair frame

You can estimate the total weight of a frame by adding up the weight of all the tubing in the frame. If you know the inner diameter, outer diameter, and length of each tube you can calculate the volume. If you know the density of the tubing material, you can calculate the total mass. See the above example for calculating the mass of a frame.

# Axial stress



## Where useful

Frame

Axles

Wheels

Bearings

## Description

Stress is defined as the force acting on an object divided by the area over which it is acting. For example, push on a table with your finger. The stress you exert on the table at the point under your finger is the force with which you push divided by the area of your finger that is in contact with the table. Materials fail by bending, tearing, breaking, or stretching when they hit a certain level of stress. Axial stress tries to pull or compress a material (from tensile and compressive forces). Shear stress tries to tear a material (from shear forces).

$F=5N$

$A_1=62mm^2$

$$\sigma_1 = \frac{5N}{62mm^2} = \frac{80645N}{m^2}$$

$$\text{Stress} = \sigma = \frac{F}{A}$$

$F=5N$

$A_2=1.3mm^2$

$$\sigma_2 = \frac{5N}{1.3mm^2} = \frac{3846154N}{m^2}$$

$\sigma_1 \ll \sigma_2$

## Example: Feeling stress with skin

Push the fat end of a pen or pencil into your skin with a certain amount of force. Now flip the pen around and use the same amount of force to push the sharp end into your skin. The sharp end hurts because it exerts a higher stress on your skin. Your body prevents you from tearing your skin by using pain to tell you if your skin is getting stressed too much. Even though you used the same amount of force in both tests, the area of the sharp end of the pencil is smaller, resulting in a higher stress on your skin.

# Behavior of metals



Where useful
Frame
Axles
Wheels
Bearings

## Description

The level of stress when a metal first starts to deform permanently under tensile or compressive stresses is called the *yield strength*. If more stress is applied to a metal past the yield strength eventually the material will break when it hits the *ultimate strength*. Shear stresses can also permanently deform a metal, and will be discussed in the next section. When engineering a wheelchair you always want to use a *safety factor* (SF), meaning you want to prevent the stresses from coming within a certain factor of the yield strength. In most cases a SF of 2 is enough but other cases require much higher SFs, up to 10 or 20.

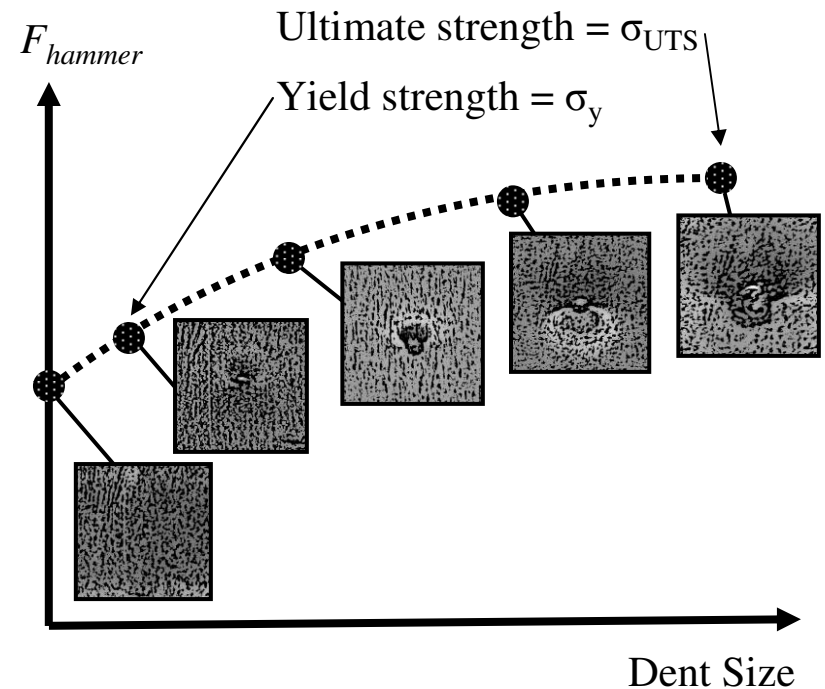

## Example: Stressing sheet metal

Take a piece of sheet metal and put it on a piece of wood. Now take an indenter and hit it lightly with a hammer. No dent is left because the material was not stressed enough to permanently deform. Now hit the material harder and harder until you first start to make a dent, which corresponds to the yield strength. Hit harder so you make bigger dents and eventually tear the metal, which corresponds to the ultimate strength. As shown in the equation above, the stress exerted on the metal is the hammer force divided by the indenter area.

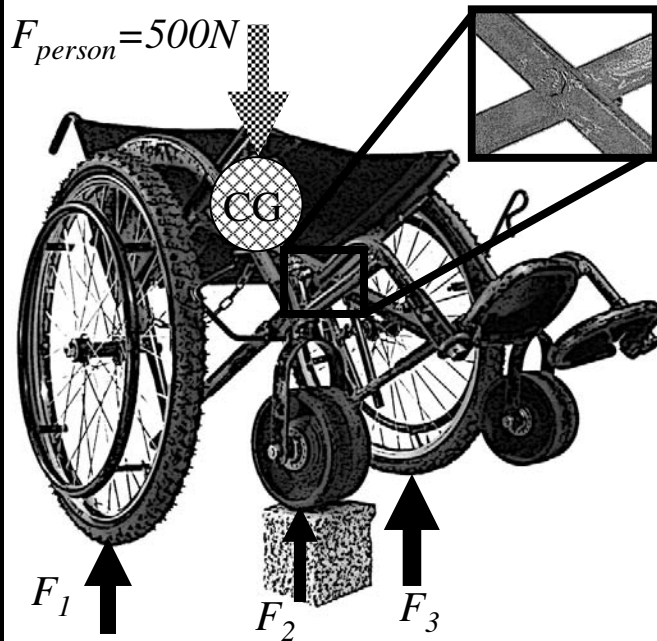

3 points contact the ground

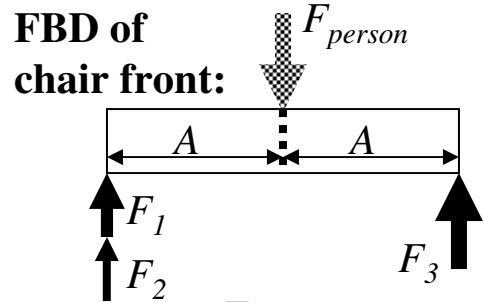

From symmetry

$$F_3 = \frac{F_{person}}{2} = 250N$$

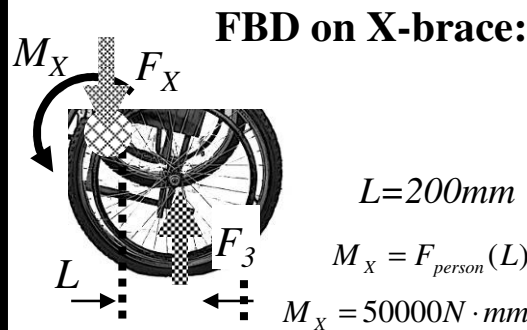

**FBD on 1 X-brace leg:**

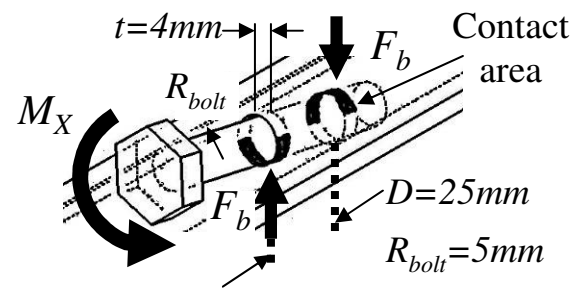

Add moments about left hole:

$$0 = F_b D - M_x \Rightarrow F_b = \frac{M_x}{D} = 2000N$$

Calculate stress on contact area:

$$\sigma = \frac{F_b}{\text{Contact area}} = \frac{F_b}{\pi R_{bolt} t} = 31.8 \frac{N}{mm^2}$$

$$\sigma = 31800000 \frac{N}{m^2} < \sigma_{y,steel} = 330000000 \frac{N}{m^2}$$

Design is safe for *static* loading but possibly not for *shock loads* (read below)

## Example: Stresses on the X-brace

When the wheelchair goes over rough ground one wheel often lifts up, as shown in the figure. This causes a moment to be transmitted through the X-brace, which causes stress on the bolt holes. To determine the stress we can first calculate the force on the left wheel ( $F_3$ ) from the FBD looking at the front of the chair. Next we look at the side of the chair and visualize the moment in the X-brace caused by  $F_3$ . Finally we calculate the stress on the bolt hole by estimating the contact area between the bolt and the leg as  $\frac{1}{2}$  the surface area of the hole. Our final answer is well below the yield stress of mild steel, but why do these holes still get over-stressed? The reason is *shock loading*, for instance when the user jumps off a curb onto the road. Shock loading can easily magnify the *static stresses* (the stresses caused by gravity when stationary) by 10 times, which in our example would raise the stress near the steel's yield strength. One way to decrease the stress would be to increase the contact area.

# Modulus and strain



Where useful
Frame
Axles
Wheels
Bearings

## Description

The *modulus of elasticity* ( $E$ ) is a material property that tells how much a material tries not to deform when it is under stress. Strain is the measure of how much a material deforms when under stress. Imagine pulling on a piece of metal and creating a stress. The material will stretch a little because of the stress. The amount it stretches divided by its original length is the strain. If you do not pull too hard the metal can spring back to its original length, which means it deformed *elastically*. When metals are deformed elastically the modulus of elasticity equals the stress divided by the strain. This relationship is shown in the example to the right.

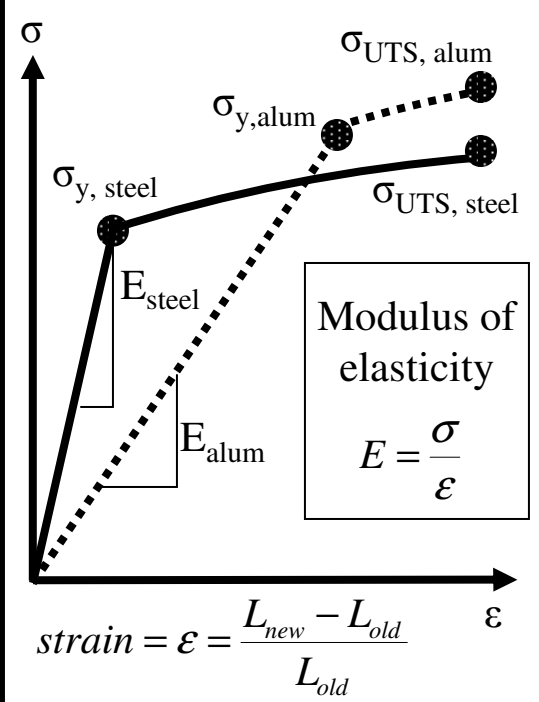

Material	E (N/mm <sup>2</sup> )	σ <sub>y</sub> (N/mm <sup>2</sup> )
Steel (mild)	200000	330
Alum. (6061)	68900	276
Rubber (Butyl)	-	17
Plastic (PVC)	2500	40

## Example: Stress, strain, modulus

In the sheet metal/indenter example, when you hit the indenter lightly it did not dent the metal. The metal deformed elastically and was able to spring back to its original shape. As shown in the graph and equation above, the stress and strain relate through the modulus of elasticity up to the yield strength of the material. Metals like steel and aluminum, shown on the graph, have different modulus values. Steel feels stiffer because it has a higher modulus, but some types of aluminum (not all) are stronger because they have a higher yield strength.

# Shear stress



## Where useful

Frame

X-brace

Wheels

Casters

## Description

*Shear stress* is the stress that tries to rip something apart. It is defined as the shear force divided by the area over which the force is acting. The shear strength of metals, the amount of shear stress to cause failure, is approximately  $\frac{1}{2}$  the yield strength. This means you can easily calculate the amount of shear stress a part can withstand by knowing the yield strength. Make sure the shear stresses are below  $\frac{1}{2}$  the yield strength. If you used a safety factor of 2, which is good engineering practice, you would make sure the shear stress is below  $\frac{1}{4}$  the yield strength.



Metal punch

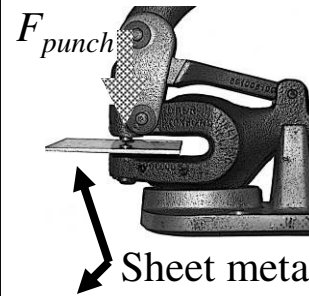

Sheet metal

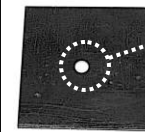

Punched hole

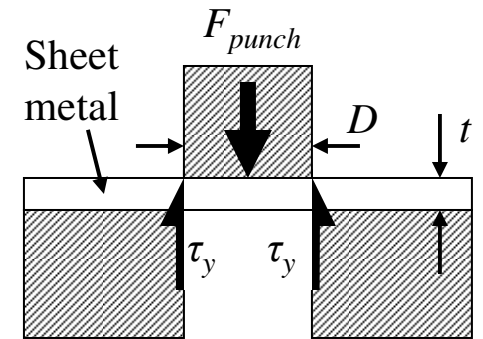

Area of metal being sheared:

$$A = \pi D t$$

Yield strength =  $\sigma_y$

Shear strength =  $\tau_y = \sigma_y / 2$

Punch force:

$$\tau_y = \frac{F_{punch}}{A} = \frac{\sigma_y}{2} \Rightarrow F_{punch} = \frac{\pi D y \sigma_y}{2}$$

## Example: Metal punch

A punch uses shear stress to make a hole in sheet metal. We can calculate the amount of force it takes to make the hole by knowing the yield strength ( $\sigma_y$ ) and thickness ( $t$ ) of the material and the diameter of the punch ( $D$ ). See the example for the equation to predict punching force. To find the force required for any punching operation, all you have to do is determine the shear area and know the material properties of the metal getting punched.

$$F_{person} = 500N$$

$$D = 10mm$$

$$\sigma_{y,steel} = 330 \frac{N}{mm^2}$$

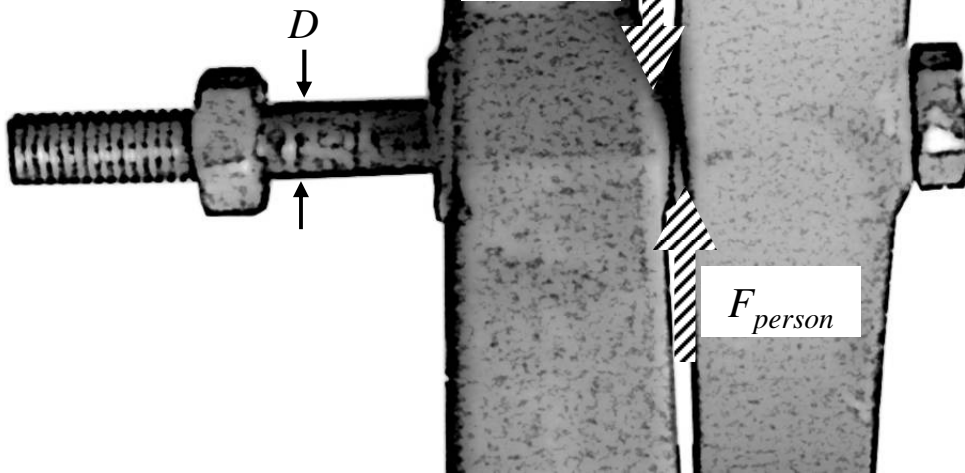

Area of metal being sheared:

$$A = \frac{\pi D^2}{4}$$

Shear stress:

$$\tau = \frac{F_{person}}{A} = \frac{500N}{\frac{\pi(10mm)^2}{4}} = 6.37 \frac{N}{mm^2}$$

$$\frac{\sigma_{y,steel}}{2} = 165 \frac{N}{mm^2} \gg \tau = 6.37 \frac{N}{mm^2}$$

Since the shear strength of the bolt is much larger than the shear stress, the bolt is plenty strong enough for the X-brace.

### Example: Shear stresses on bolts

Sometimes bolts are subjected to shear stresses. One example is in the X-brace pivot of a wheelchair. Under normal conditions, when the wheelchair is upright and on level ground, no shear stress exists in the bolt. But as the wheelchair frame flexes, shear stresses can be exerted on the bolt where the two legs of the X-brace meet. If you know the forces the legs of the X-brace apply to the bolt and the diameter of the bolt, you can calculate the amount of shear stress in the bolt. To estimate the shear force you can use the weight of the person in the chair. Remember shock loads will also exist, so the actual forces might be many times the person's weight. See the above example for the shear stress calculation and to confirm the bolt is strong enough to withstand shock loading.

# Bending stress



## Where useful

Frame

Axles

## Description

When a part is bent the applied moment creates stresses in the material. On one side of the part the material is stretched and thus has tensile stresses. On the other side the material is compressed by compressive stresses. Most metals can be bent a little bit (elastically) and spring back to their original shape. If you bend metal too far it will permanently deform because the tensile and compressive stresses will become larger than the yield stress of the material. As you will see in the next section, the moment in a part directly relates to the *bending stresses*.

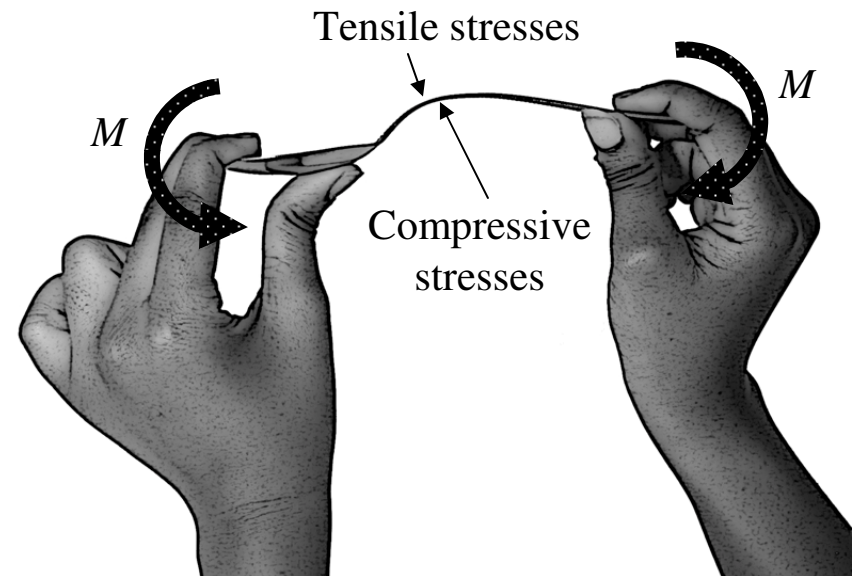

## Example: Bending a spoon

Take the handle of a spoon with the flat side up. Bend the handle slightly and it will spring back. Bend it a little farther and it will be permanently bent. When the spoon is bent downward (as shown) the top of the spoon is being stretched by tensile stresses and the bottom is being compressed by compressive stresses. The spoon permanently bends when tensile and compressive stresses become larger than the yield stress of the metal from which the spoon is made.

# Moment of inertia



## Where useful

Frame

Axles

## Description

The strength and stiffness of a part depends greatly on the part's geometry. When a part is bent the material at the outer surface feels the highest stress. If the part is made thicker the material at the outer surface has more leverage, so the part will be stronger. The part will also be stiffer because it will bend less under a given moment. The moment of inertia ( $I$ ) is a measure of how well the part geometry uses material to counteract bending moments. As you will see on the next page, the maximum stress in a part is directly related to the applied moment, the thickness of the part, and the moment of inertia.

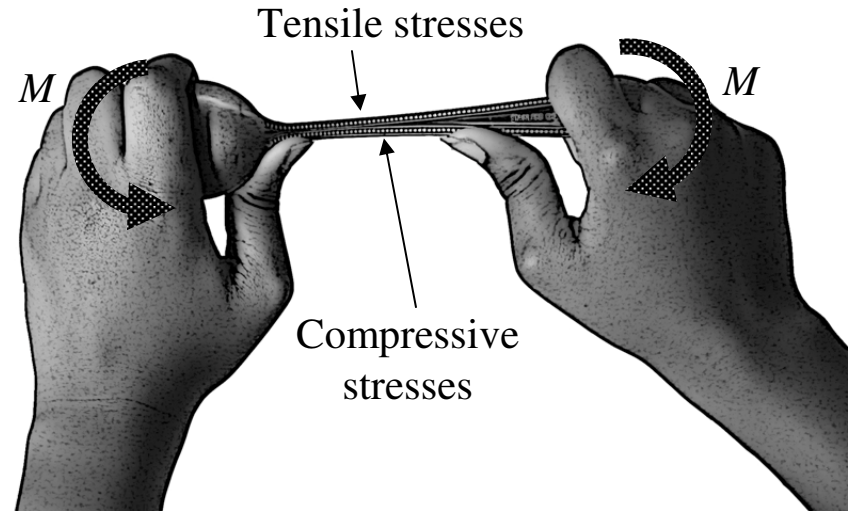

## Example: Bending a spoon two ways

Use the same spoon you bent in the last example. Now flip it so the thin side is facing up and try bending it. The amount of material did not change but the spoon seems stronger and stiffer because the moment of inertia is higher with the thin side up than with the flat side up. If you know the moment applied to the part, and the moment of inertia, you can find the maximum stress the part experiences. See the next example for the moment of inertia of a variety of shapes as well as the maximum stress felt by each shape when a moment is applied.

Loading condition for max stress equations

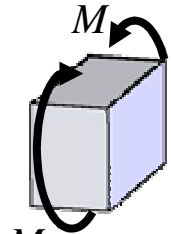

$M$

Moment of inertia =  $I$

Max stress

=  $\sigma_{\max}$

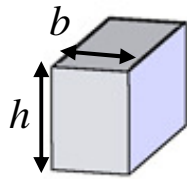

$$I = \frac{bh^3}{12}, \sigma_{\max} = \frac{Mh}{2I}$$

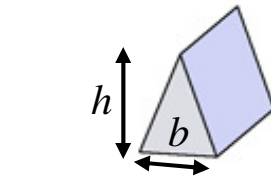

$$I = \frac{bh^3}{36}, \sigma_{\max} = \frac{2Mh}{3I}$$

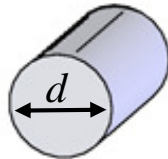

$$I = \frac{\pi d^4}{64}, \sigma_{\max} = \frac{Md}{2I}$$

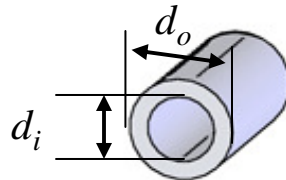

$$I = \frac{\pi}{64}(d_o^4 - d_i^4), \sigma_{\max} = \frac{Md_o}{2I}$$

### Solid axle

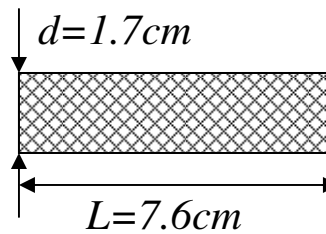

$$I = \frac{\pi d^4}{64}$$

$$\sigma_{\max} = \frac{Md}{2I} = \frac{32M}{\pi d^3} = 2.07M$$

$$\text{mass} = m$$

$$m = \rho \frac{\pi d^2}{4} L = 17.3\rho$$

### Hollow axle

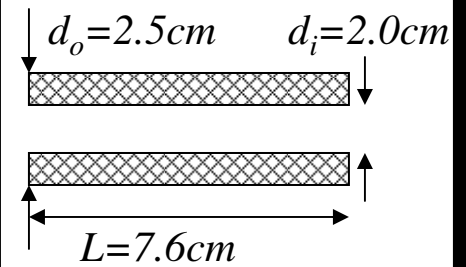

$$I = \frac{\pi}{64}(d_o^4 - d_i^4),$$

$$\sigma_{\max} = \frac{Md_o}{2I} = \frac{32Md_o}{\pi(d_o^4 - d_i^4)}$$

$$\sigma_{\max} = 1.10M$$

$$m = \rho \frac{\pi(d_o^2 - d_i^2)}{4} L = 13.4\rho$$

## Example: Shape/moment of inertia

Increasing the moment of inertia of a part makes it both stronger and stiffer. The geometry of the part determines the moment of inertia. This fact is very powerful, as it allows parts to be made stronger without adding more material. Consider the frame of a bicycle; the tubes are hollow to maintain a large moment of inertia while keeping the weight low. The above figure shows some common shapes of wheelchair components and how to calculate the moment of inertia and the maximum stress on the part under an applied moment.

## Example: Stress in wheelchair axle

Using your knowledge of moment of inertia you can calculate the strength of a rear wheelchair axle. The figure above shows a hollow and solid axle. Both axles are the same length, have the same moment applied ( $M$ ), and are made of the same material ( $\rho$ ). As you can see from the calculation, the hollow axle is 88% stronger (because it has a lower stress under the same moment) and 29% lighter than the solid axle. By just changing the geometry (and moment of inertia) a part can be made significantly stronger and lighter.

# Stiffness vs. strength



Where useful
Frame
Axles
Wheels
Bearings

## Description

*Stiffness* ( $k$ ) is defined as the force applied to an object divided by the resulting deflection. For example, when you push on a spring with a force it compresses, resulting in a deflection. The stiffness of a material depends on the modulus of elasticity. The stiffness and strength of a part depends on the modulus and the part's geometry. Just because something is stiff does not mean it is strong. Rubber bands are strong but have very low stiffness. Glass is very stiff but not strong when it is bent. Steel is a great material because it is stiff and strong. It makes a wheelchair rugged and feel sturdy.

Column	Cantilevered beam	Center-loaded beam
$\delta = \text{deflection}$ $k = \frac{F}{\delta}$ $k = \frac{EA}{L}$	$k = \frac{F}{\delta}$ $k = \frac{3EI}{L^3}$	$k = \frac{F}{\delta}$ $k = \frac{48EI}{L^3}$

## Example: Stiffness of different parts

All parts have a certain amount of stiffness. The stiffness of a part depends on the material and the geometry. Equations for the stiffness of different parts are given in the figure above. Notice that the stiffness of each part has the modulus of elasticity ( $E$ ) in the equation. This means the part can be made stiffer if it is made from a material with a higher modulus of elasticity. In the beam examples, stiffness also increases with the moment of inertia.

# Stress and failure

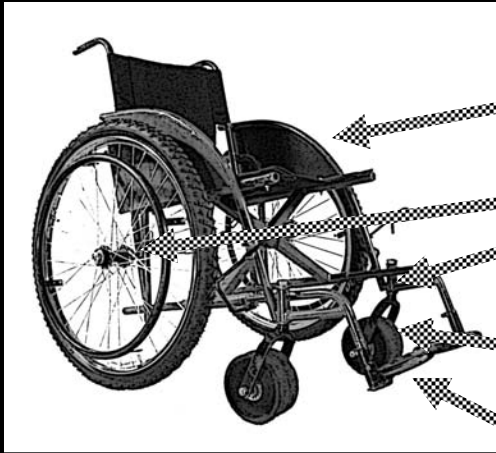

Where useful
Frame
Axles
Bearings
Casters
Footrests

## Description

Parts in wheelchairs can fail from different kinds of stresses, including compressive stresses (in bearings), bending stresses (in axles), or shear stresses (in cotter pins). It is the job of an engineer to determine what type of stress may cause failure. In most instances one kind of stress will be much higher than the others so the part will fail due to the highest stress. In other instances if two stresses are about the same level, for example bending and shear, you have to use an equivalent stress. The equivalent stress can be approximated as 2 times the largest individual stress (see the example for using an equivalent stress).

For each axle:  $d=17\text{mm}$ ,  $I=4100\text{mm}^4$

$$F_{\text{vert}} = 500\text{N}, M_{\text{axle}} = F_{\text{vert}}(L)$$

$$\sigma_{\text{shear}} = \frac{F_{\text{vert}}}{A}, \sigma_{\text{bend}} = \frac{Md}{2I}$$

### Long-normal



$$L=76\text{mm}$$

$$\sigma_{\text{shear}} = 2.2 \frac{\text{N}}{\text{mm}^2}$$

$$\sigma_{\text{bend}} = 78.9 \frac{\text{N}}{\text{mm}^2}$$

$$\Rightarrow \sigma_{\text{bend}} > \sigma_{\text{shear}}$$

### Medium



$$L=3\text{mm}$$

$$\sigma_{\text{shear}} = 2.2 \frac{\text{N}}{\text{mm}^2}$$

$$\sigma_{\text{bend}} = 3.1 \frac{\text{N}}{\text{mm}^2}$$

$$\Rightarrow \sigma_{\text{bend}} \approx \sigma_{\text{shear}}$$

use  $2\sigma_{\text{bend}}$  as  $\sigma_{\text{max}}$

### Short



$$L=0.5\text{mm}$$

$$\sigma_{\text{shear}} = 2.2 \frac{\text{N}}{\text{mm}^2}$$

$$\sigma_{\text{bend}} = 0.5 \frac{\text{N}}{\text{mm}^2}$$

$$\Rightarrow \sigma_{\text{shear}} > \sigma_{\text{bend}}$$

## Example: Axle length and stress

The axles in this example are under simple cantilevered loading. In a normal to very long axle bending stresses will be the largest type of stress. In a very short axle the shear stresses will dominate. In a medium length axle the shear and bending stresses will be about the same size. In this case an equivalent stress has to be used. If the equivalent stress reaches the yield stress of the material the axle will fail. See the above examples for calculating stresses for each type of axle.

# Stress concentration

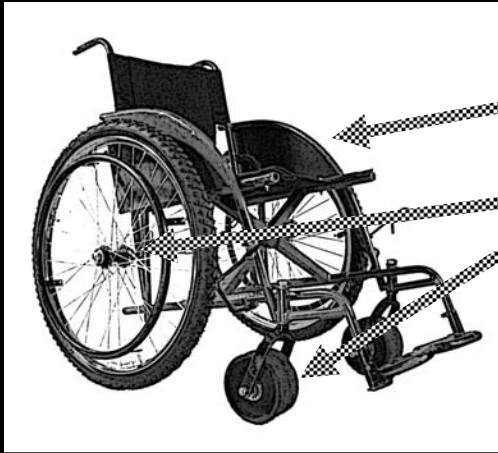

Where useful
Frame
Axles
Casters

## Description

When a part has a sudden change in geometry the stresses will be higher in that area, resulting in a *stress concentration* ( $K$ ). The stress concentration is a number that tells you how much the geometry intensifies the stress. To find the actual stress at a location, first calculate the stress without the concentration and then multiply by the stress concentration (see the example for stress concentrations in different geometries). As a conservative estimate, most stress concentrations are about 3. This means if you have a sudden change in geometry, plan for the stresses at the change to be about 3 times larger than in the rest of the part.

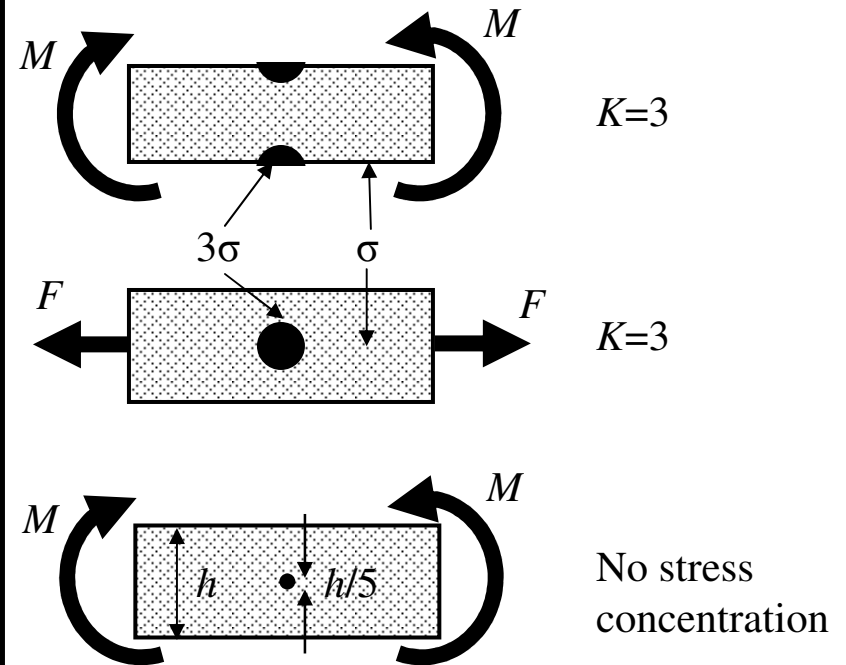

## Example: Common concentrations

The figure above shows stress concentrations for common geometries. You can decrease stress concentrations by using a more gradual geometry (example: use a fillet instead of a sharp corner) Note: If you need to put a hole in a part that has a moment applied to it, drill the hole near the center, as the highest stresses will be on the outer surface of the part (see the figure). If the hole diameter is small compared to the height of the part (less than 1/5<sup>th</sup>) you do not have to account for the stress concentration.

# St. Venant's

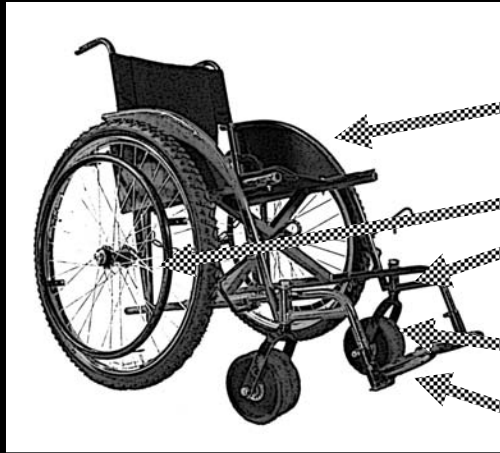

## Where useful

Frame

Axles

Bearings

Casters

Footrests

## Description

A good design rule of thumb to remember is that effects (for example stress concentrations or clamping force) on one part of a machine at one point are not felt 3 to 5 characteristic lengths away from that point. This is called *St. Venant's Principle*. A characteristic length is the important dimension at a specific location in a machine. It may be a hole diameter, the thickness of a plate, or the diameter of a shaft. The opposite is also true: if you want a part to feel an effect (for example being clamped firmly into place) it should be held over 3 to 5 characteristic lengths.

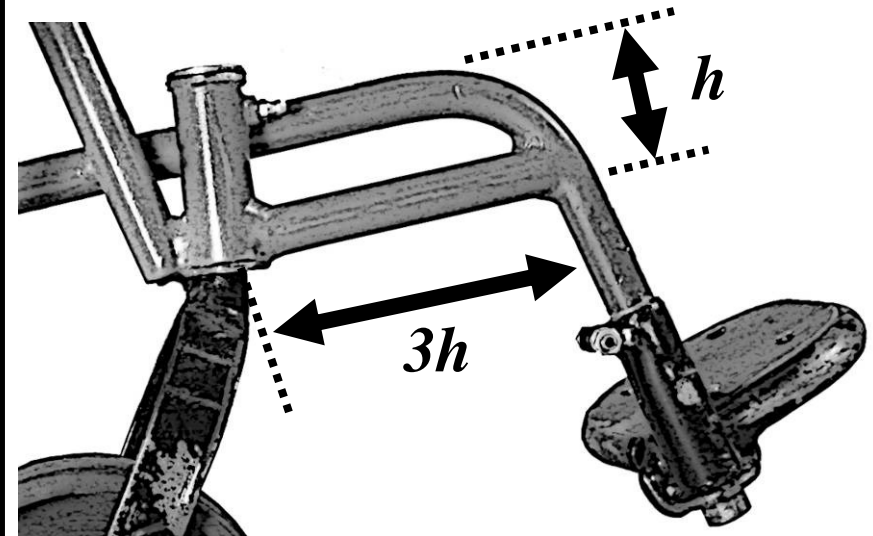

## Example: Caster frame design

St. Venant's principle is very useful when designing wheelchair frames. If any part protrudes more than 3 to 5 characteristic lengths away from the wheelchair (the characteristic length could be the tubing diameter or the part height) then the frame might not feel stiff. The footrest frame on African-made wheelchairs is very well designed. The footrests are cantilevered but do not extend more than 3 to 5 times the height of the caster frame.

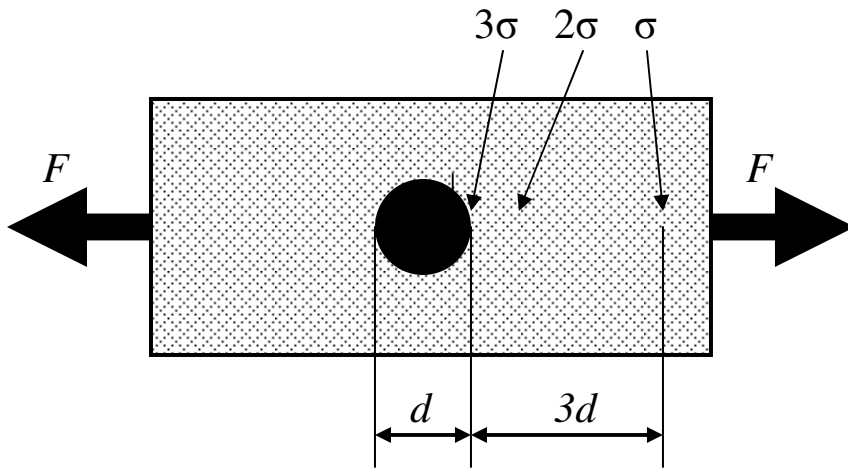

### Example: Stress far from a hole

You learned the stress concentration at a hole in a part under tension will be approximately 3. As you move away from the hole the stresses return to a level as if the hole was not there. In this case the characteristic length is the hole diameter. The part does not feel the stress concentration 3 to 5 diameters away from the hole.

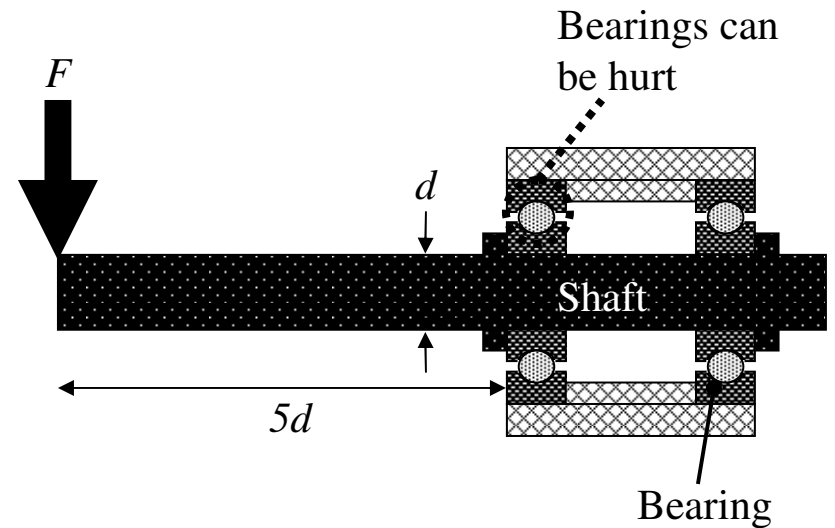

### Example: Cantilevered axles

If an axle extends too far from the bearings supporting it the axle will flex and not feel stiff. The length an axle is cantilevered should not be more than 3 to 5 times its diameter. If the axle is cantilevered any more the bearings can be hurt by axle deflection.

# Structural loops



## Where useful

Frame

Caster frame

Footrests

## Description

If you want a frame or any kind of structure to be stiff you should design the components of the structure to be close together. A structural loop is a visual way of representing how forces travel through a structure. If the path the forces take is narrow, the structure will be stiff. For example, picture the forces that travel through the caster frame. The forces start at the ground and move up through the caster barrel. At the top of the barrel they travel into the frame, loop around the frame, and come back to the bottom of the barrel. Now imagine if the caster frame was very long – the structural loop would be larger and the frame would be less stiff.

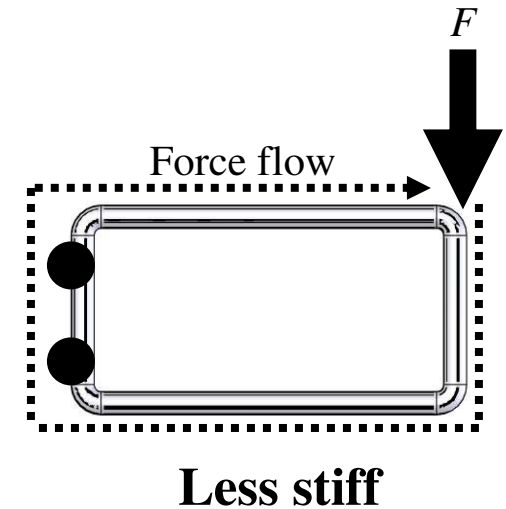
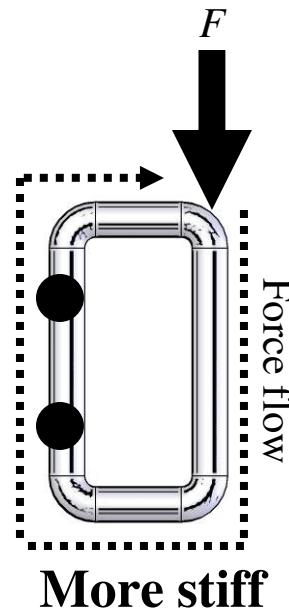

## Example: Structural loops in frames

Imagine you are evaluating whether to use two different frame layouts. One frame is a narrow rectangle and another is a long rectangle. Each frame has a force applied to the end, as shown in the figure. Follow the force flow through the frame and back to the point where the force is applied. The narrow frame will be stiffer because it has a tighter structural loop.

# Golden ratio

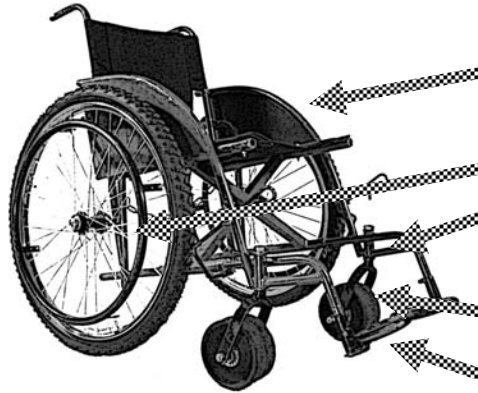

## Where useful

Frame

Axles

Bearings

Casters

Footrests

## Description

The *golden ratio*, 1.618 to 1, is a proportion commonly found in nature that is also useful in many engineering applications. Your body is built around this ratio; it is approximately the ratio between your overall height and the distance from your hips to the ground. Many other animals and plants are built around this proportion. When used in engineering the golden ratio makes devices look aesthetically pleasing and perform well. For example, the distance between the tires along the length of a car is usually about 1.6 times the width of the car.

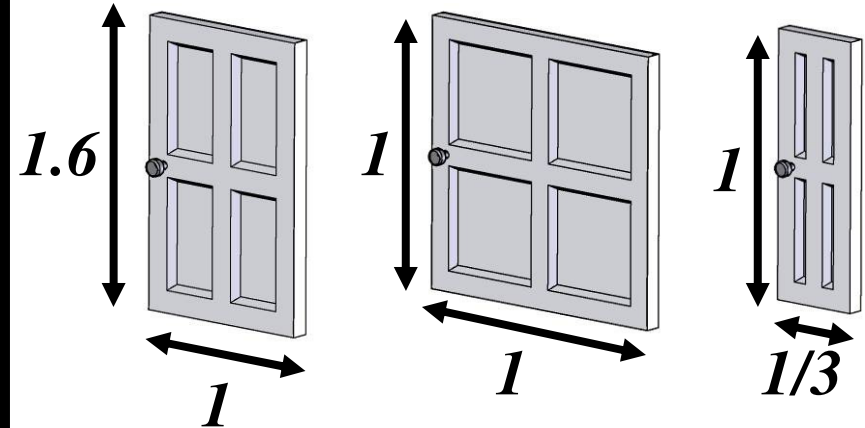

## Example: Door proportions

Look at the different doors in the above example. Which one looks the most attractive? The door that fits the golden ratio has the most pleasing proportions.

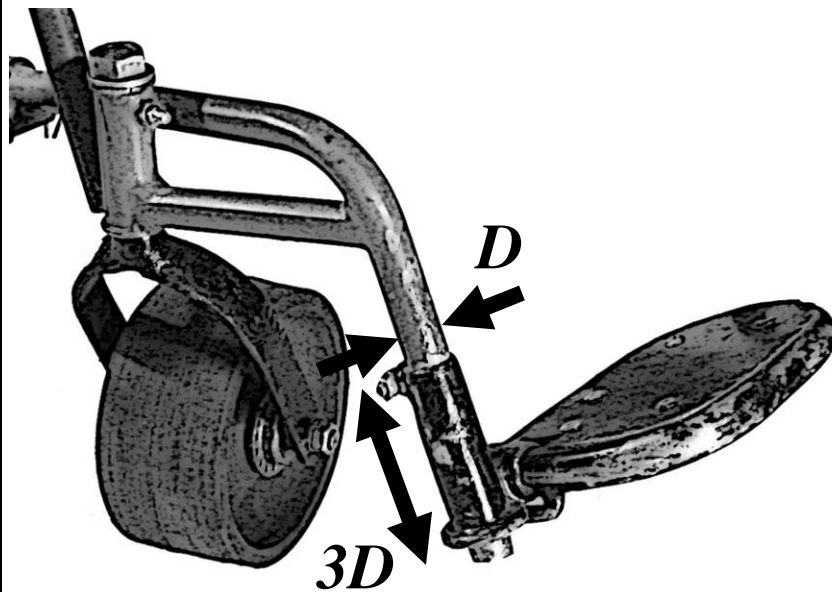

### Example: Concentric cylinders

When you want one cylinder to slide within another make sure the length in which they overlap is at least 1.6 times the diameter. If the overlap distance is smaller than the golden ratio the cylinders might jam and not slide easily against each other. If space allows, using a ratio larger than 1.6 to 1 will make the device perform even better. The footrest clamp on the African-made wheelchair is well designed, as the clamping cylinder overlaps the frame tube by 3 times the tube diameter.

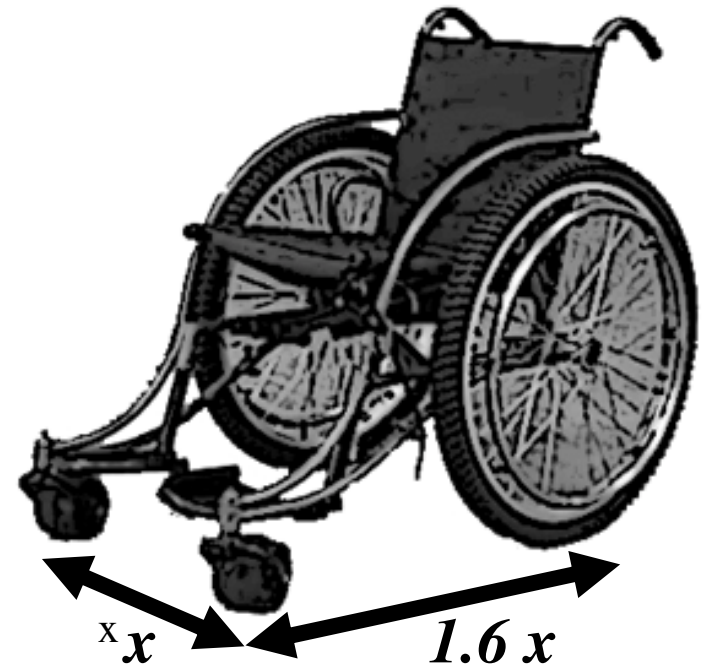

### Example: Whirlwind “Liviano”

Pictured above is Whirlwind Wheelchair’s newest design, called the “Liviano.” One reason this chair looks very attractive is because it has proportions near the golden ratio. These proportions also make it perform well – the chair is well balanced and can easily climb over obstacles.

# Exact constraint

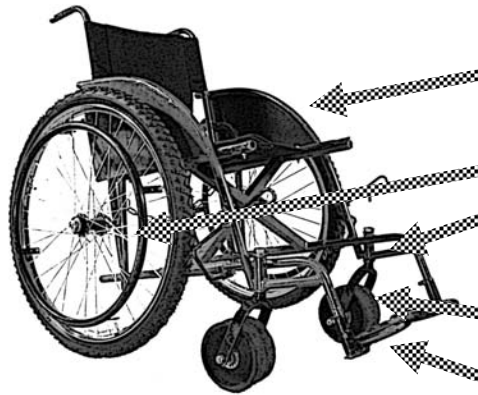

## Where useful

Frame

Axles

Bearings

Casters

Footrests

## Description

An object can move 6 different ways, each of which is called a *Degree of Freedom* (DOF); it can rotate in 3 different DOFs and translate (move in a straight line) in 3 different DOFs. Any movement an object makes is composed of some or all of these DOFs. You can constrain DOFs to limit an object's movement. *Exact constraint design* is a method of using only one constraint for each unwanted DOF. As you will see in the examples, over constraining objects is often necessary but in other instances can make them deform or break.

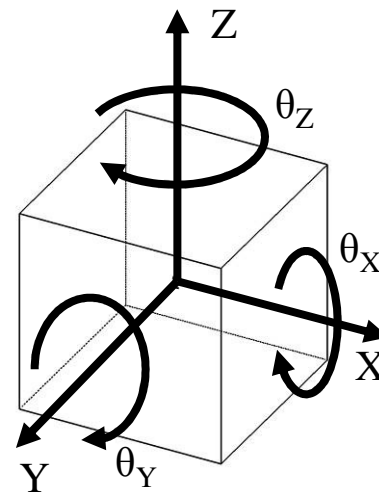

DOFs of free-floating cube

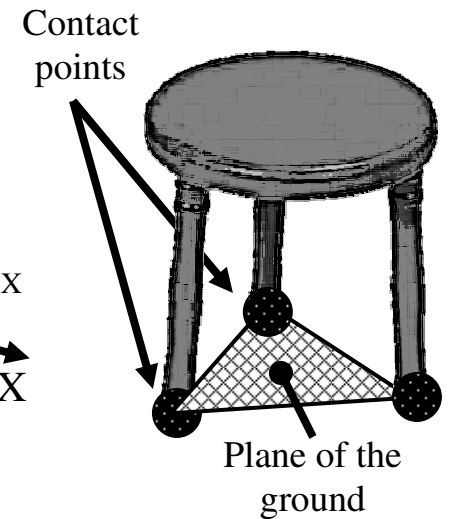

Exactly constrained milk stool

## Example: DOFs of objects

The cube shown is not touching anything so it has 6 DOFs: 3 rotational (curved arrows) and 3 translational (straight arrows). The 3-legged milk stool has three points that touch the ground. Each point acts as a constraint, thus the stool has only 3 DOFs. From geometry, 2 points define a line and 3 points define a plane. No matter how rough the surface on which the stool sits, three legs will always touch 3 points that define the plane of the ground. This is why a milk stool does not rock back and forth, no matter what kind of ground it is on.

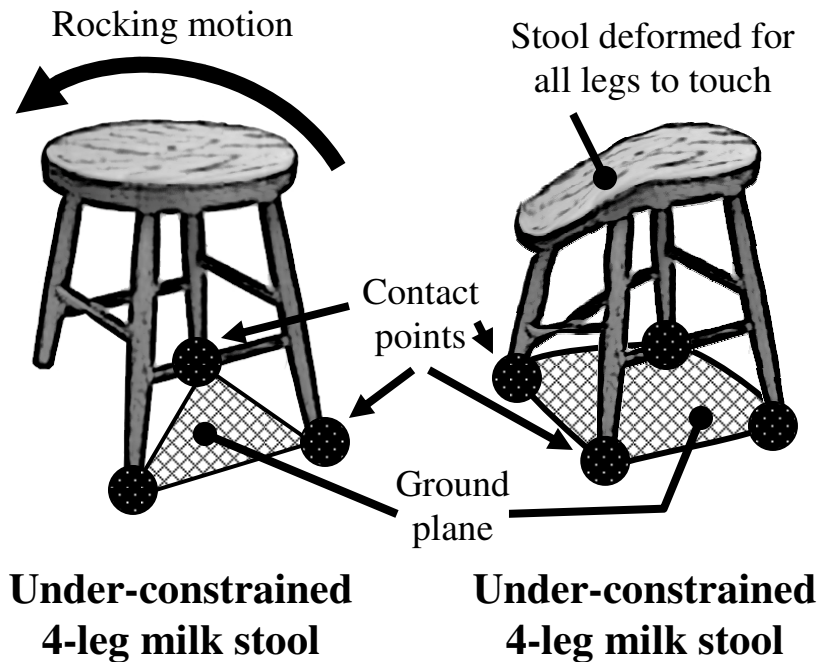

### Example: 3 and 4-legged stools

As you saw in the last example a 3-legged stool will always touch the ground at 3 points, which makes it *exactly constrained*. A 4-legged stool tries to touch the ground with 4 points but the plane of the ground is defined by 3 points. This means if 1 leg is too long or short only 2 the legs will touch the ground and the stool will rock back and forth between the other 2 legs. In this case the stool is *under-constrained*, as there are 2 constraints when we need 3. If we forced all 4 legs to touch the ground the table would flex and would be *over-constrained*.

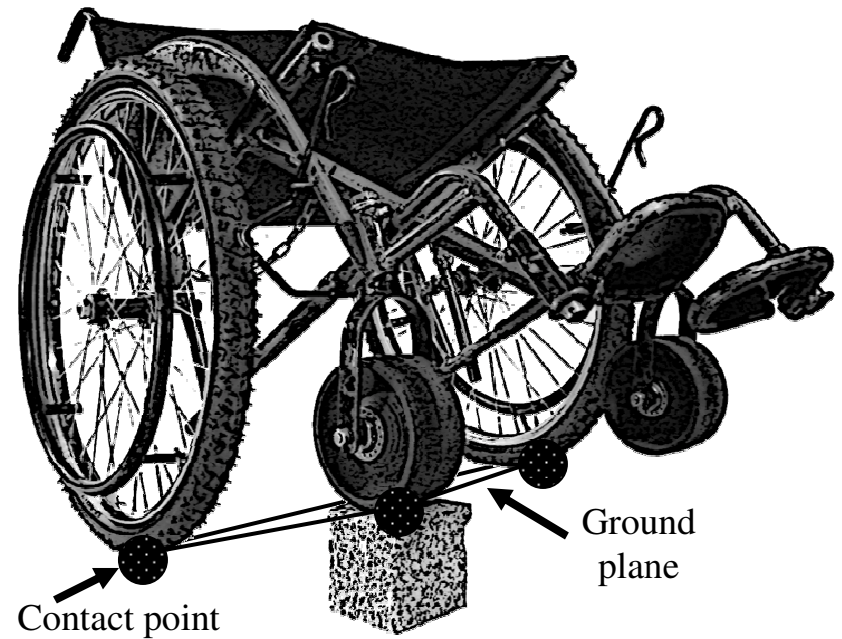

### Example: 3 and 4 wheeled chairs

A wheelchair will act the same way as a stool on rough ground. A 3-wheeled chair will always have its wheels touching the ground while a 4 wheeled chair will have one wheel lift off as it goes over rough terrain, as shown in the figure. A 3-wheeled chair will have a lower tipping angle, as the CG is closer to the line between the front and rear wheel contact points, but it may be more comfortable to use on rough ground. When deciding whether to prescribe a 3 or 4-wheeled chair the types of ground over which the user travels should be considered.

# Mounting bearings



## Where useful

Rear wheels

Caster barrels

Casters

## Description

It can be very important to use exact constraint design when mounting bearings. Over-constraining the bearings can damage the marbles and races. In the example with the 4-legged stool, if all 4 legs were forced to touch the ground the stool could flex too much and break. If a bearing is forced into an unnatural configuration it can deform, bend, or shatter. Think about the constraints on an axle – the axle should only have 1 DOF (rotation), and so it must have 5 constraints. If the bearings provide more than 5 constraints the shaft or bearings could become damaged.

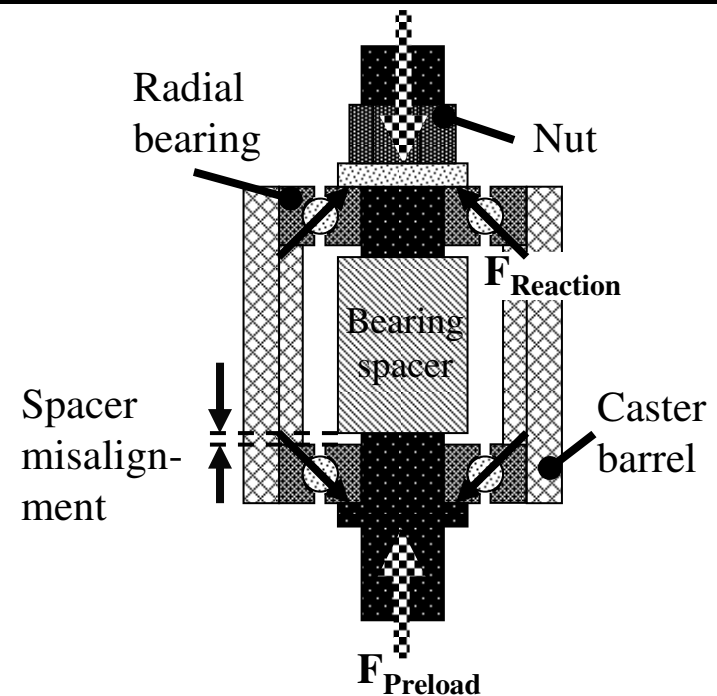

## Example: Caster barrel bearings

The figure above shows the configuration of the castor barrel assembly in an African-made wheelchair. This design has the potential to over-constrain and damage the bearings if the spacer is too short. As the nut is tightened the marbles will be sheared. To picture this imagine there is no spacer. The tightening force of the nut would transfer into the bearing and shear the marbles, as shown in the figure.

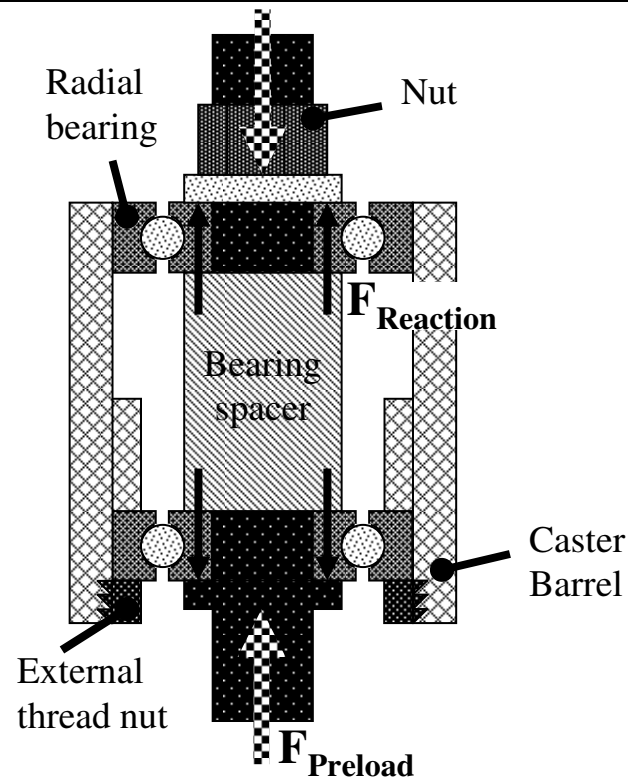

### **Example: Under-constrained and exactly constrained caster barrel bearings**

In the caster barrel the assembly, if the spacer is too long the bearings will be under-constrained and able to slide up and down a little. This case is better than over constraining the bearings. No matter how precisely the spacer and caster barrel are made they will not be perfect – the assembly will either be over or under-constrained. There is a way to assemble the bearings so they are exactly constrained, as shown in the second picture of the figure. In this design all the forces from the nut are transferred through the bearing race and not through the marbles. Nut tightness will never harm the marbles. Study the assembly – it cannot slide up and down because the internal threaded nut holds the assembly in place.

# Bearing types



## Where useful

Rear wheels

Castor barrels

Casters

## Description

Radial bearings are designed to take radial loads. Angular contact bearings are designed to take radial and axial loads. An axial load is a force acting in the direction of the center of the shaft and a radial load is a force acting perpendicular to the shaft, as shown in the example. It is the job of an engineer to determine what kinds of forces will act on a bearing (radial, axial, or both), and choose the best bearing for that particular machine.

## Radial bearing



[www.ntnamerica.com](http://www.ntnamerica.com)

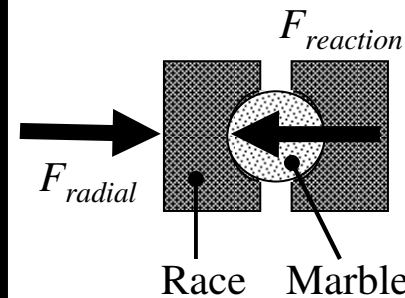

## Angular contact bearings



[www.gsportbmx.co.uk](http://www.gsportbmx.co.uk)

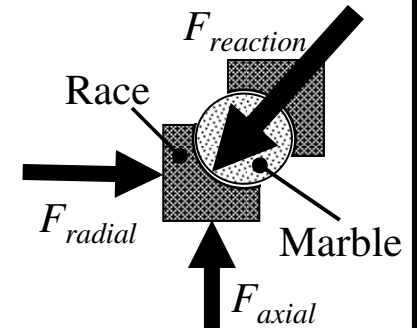

## Example: Types of bearings

The figure above shows a radial and an angular contact bearing. Notice how the races of each bearing are different. The angular contact bearing has angled races so it can support both radial and axial forces. The radial bearing is not good for axial forces. There is not much area of the race to support the marbles when they are loaded in the axial direction.

### Stem bearings

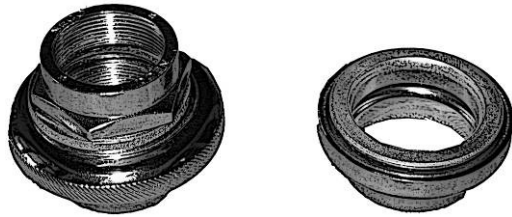

Assembled view



Disassembled view

### Front hub

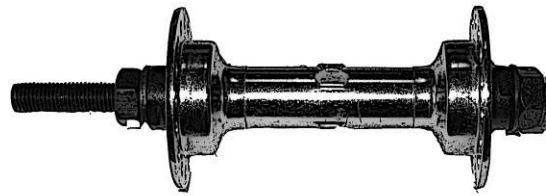

Assembled view

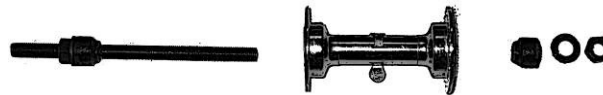

Disassembled view

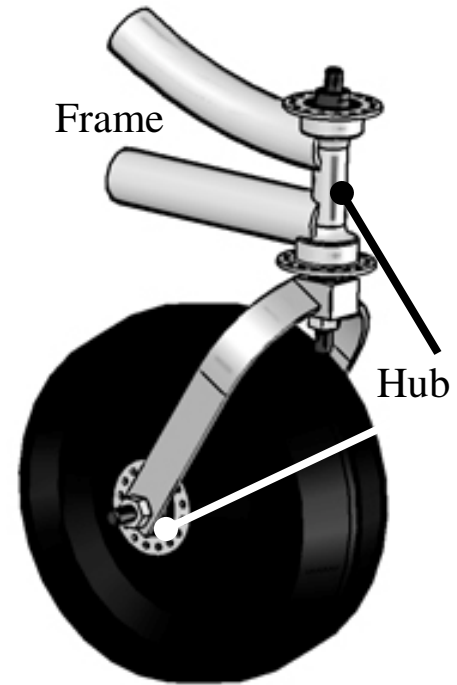

## Example: Angular contact bearings used in bicycles

Angular contact bearings are used in bicycles because bicycles experience both radial and axial forces. These bearings may be good alternatives to the radial bearings used in wheelchairs, especially in caster barrels where the highest forces are axial. Different types of angular contact bearings are made for different areas of the bicycle, such as the hubs and stem. Bicycle bearings are usually over-constrained but are designed with a lock nut. When you install a bicycle bearing first tighten the marbles so they are securely in place, and then tighten the locknut to keep the assembly from coming apart.

The figure above shows a concept for a caster barrel and caster design using bicycle hubs. The caster barrel is made from a bicycle hub welded directly to the wheelchair frame. Some wheelchair manufacturers already use bicycle hubs pressed into molded rubber casters – the African-made wheelchair shown throughout this manual has this caster design.

# Bearing lubrication



## Where useful

Rear wheels

Caster barrels

Casters

## Description

It is important to keep bearings lubricated with grease. Grease is composed of soap and oil. The soap keeps the oil from running out of the bearing and insures it remains under the bearing marbles. When the bearing is lubricated properly the marbles never touch the race and actually roll on a thin film of oil. It is very important to keep bearings clean, as small particles of dirt can damage the marbles and races.

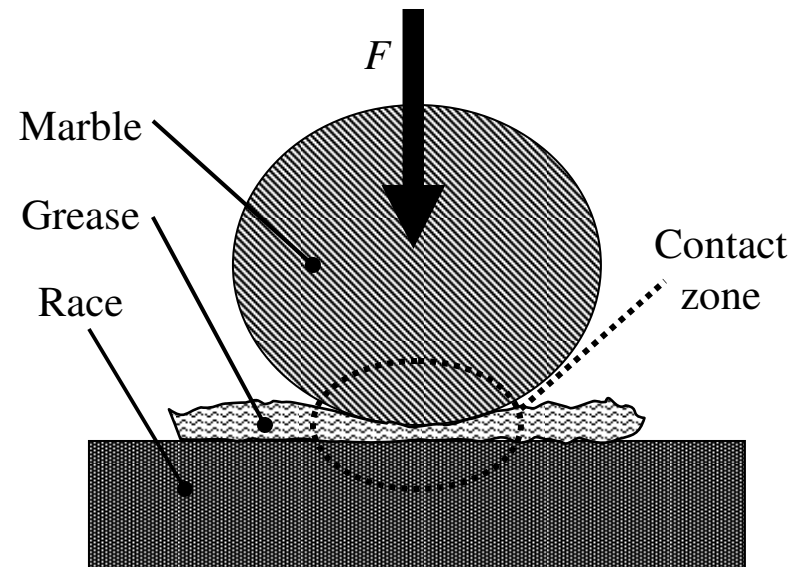

## Example: Grease under marbles

The figure above shows grease wedged between the bearing marble and race. Grease becomes very stiff and acts almost like a solid when it is squeezed between the marble and the race in the contact zone. This is how it prevents getting squeezed out when the bearing is loaded. The grease film is very thin, only a few millionths of a meter thick. It is extremely important to keep the bearings clean, as dirt within the grease film can damage the marbles and races.

# Lean manufacturing

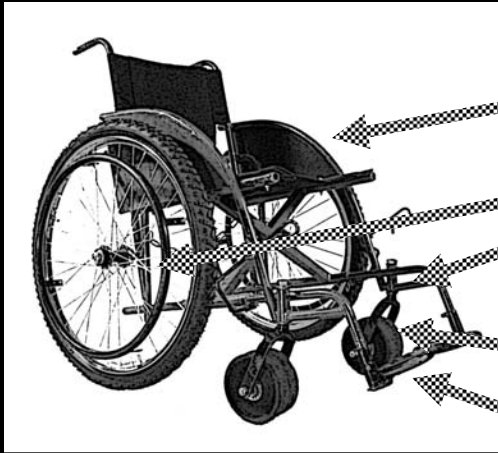

## Where useful

Frame

Axles

Bearings

Casters

Footrests

## Description

*Lean manufacturing* is a term used to describe manufacturing practices and strategies that reduce cost and production time. The lean manufacturing techniques presented in this section may or may not be useful to your workshop. Before implementing these strategies the workshop should estimate or run an experiment to see whether or not the strategy can save time and/or money.

## Outsourcing

*Outsourcing* is a term to describe hiring another company to make components instead of making them within your wheelchair workshop. Many wheelchair workshops already outsource caster wheels by having the rubber molded at another facility. For parts that require many hours to fabricate or the use of a special machine, one should consider the cost and benefit of producing the part within the wheelchair workshop or at another company. For example, there are wheelchair parts which need to be turned on a lathe. If the profit made from those parts takes more than a few years to equal the cost of the lathe, those parts should probably be outsourced to a company that specializes in metal fabrication. The money that would be used to buy a lathe could be invested elsewhere within the workshop.

## Pull method for acquiring parts

The *pull* method is a strategy where a company buys parts only when needed. Instead of storing a large inventory of parts, the company will make or order parts when necessary. There are cases when parts do need to be stored, for

example if they can only be bought in large quantities or if it is faster to make many parts at one time. The pull strategy is sometimes useful because it decreases inventory size, which reduces the required workshop size. Also, by purchasing a few parts at a time the company can avoid paying a lot of money at once.

### **Minimal weight design**

Weight should be considered when designing a wheelchair. Reducing weight not only makes the chair easier to use, it also lowers the material cost. One weight-reducing strategy is to design your frame so all the features add strength. Try to avoid features that add weight but do not add strength. Another strategy is to maximize the strength and minimize the weight of the frame tubing. Review the section of this manual on volume and moment of inertia calculations. Calculate the moment of inertia and weight for a 1 meter section of all the available sizes of steel tubing you can buy. Then find which tubing geometry has the highest ratio of moment of inertia divided by the weight. This tube will have the best strength to weight ratio and can be used to make the strongest frame at the least weight. You will

have to check that the tubing size is practical. Even if it has the best strength to weight it might not be a sensible choice. For example, if the diameter is 10 centimeters and the weight is 50 kilograms per meter, the tubing is too big and heavy to be used in a wheelchair.

### **Utilize purchased parts**

Just like you do with outsourcing, consider both material and labor costs of parts that have to be fabricated. If you can buy parts that are made in China or India, they may save you a lot of money. You will have to compare cost with reliability of the parts, as you want to maintain high-quality wheelchairs.

### **Using bicycle parts**

The use of bicycle parts in wheelchairs has many advantages. Bicycle parts are often available throughout Africa, they can be easily disassembled to be cleaned and greased, and they are easily repaired by bicycle mechanics. Bicycle parts are often much cheaper than other parts that perform the same function. For example, in Tanzania the majority of the parts in hand-powered tricycles are purchased bicycle

parts. By using these parts tricycle manufacturers have to fabricate very few items, which greatly reduces their production cost. They are able to sell tricycles for \$100US less than most Tanzanian-made wheelchairs.

### **Single jig/symmetric frame design**

A wheelchair has a left and right side. Some components are only used on one side or the other. Manufacturing time for a wheelchair can be reduced if parts can be used on both sides. For example, if the frame components on each side of a wheelchair were the same, only one jig would be required during fabrication. Making “universal” parts which work on both sides of the chair also decreases the number of different parts you have to keep in your inventory.